



TAC Xenta[®] 451/452

Analog Input and Output Module

4 Sep 2002



TAC Xenta 451 and 452 are Analog Input/Output modules in the TAC Xenta family. They are used as expansion modules for the TAC Xenta controllers, connected by the common network.

Both modules have four universal inputs, four thermistor inputs and two analog outputs. The universal inputs can also be used as digital inputs / pulse counters.

In addition, TAC Xenta 452 is equipped with LED status indicators, one for each universal input when used as digital input, and manual override for the analog output values. The LED colors, red or green, are individually selectable through switches under the front cover.

TAC Xenta 451/452 is associated with a specific controller with the assistance of the TAC Menta graphical tool.

If there are several controllers and I/O modules in the same network, a special Device Configuration Tool PC program is used during installation.

The input/output status can be checked from the TAC Xenta OP operator panel connected to any TAC Xenta controller in the same network. TAC Xenta OP has a display and a minimum number of push buttons to take readings and alter settings.

TECHNICAL DATA

Supply voltage	24 V AC $\pm 20\%$, 50/60 Hz or 19–40 V DC
Power consumption	max. 2 W
Transformer sizing	4 VA
Ambient temperature:	
Storage	-20 to 50 °C (-4 to 122 °F)
Operation	0 to 50 °C (32 to 122 °F)
Humidity	max. 90% RH non-condensing
Mechanical:	
Enclosure	ABS/PC
Enclosure rating	IP 20
Dimensions (mm)	see diagram
Weight	0.5 kg (1.1 lbs)
Universal Inputs (U1–U4):	
Quantity	4
– as Digital Inputs;	
Voltage across open contact	26 V DC
Current through closed contact	4 mA
Pulse input duration	min. 80 ms
– as Thermistor Inputs;	
TAC thermistor sensor	1800 ohm at 25 °C (77 °F)
Measuring range	-50 to 150 °C (-58 to 302 °F)
Measuring precision	see table overleaf
– as Voltage inputs;	
Input signal	0–10 V DC
Input resistance	100 kohm
	accuracy within 1% of full scale
Thermistor inputs (B1–B4):	
Quantity	4
TAC thermistor sensor	1800 ohm at 25 °C (77 °F)
Measuring range	-50 to 150 °C (-58 to 302 °F)
Measuring precision	see table overleaf
Analog outputs (Y1–Y2):	
Quantity	2
Control voltage	0–10 V DC
Control current, short-circuit proof	max. 2 mA
Deviation	max 1%

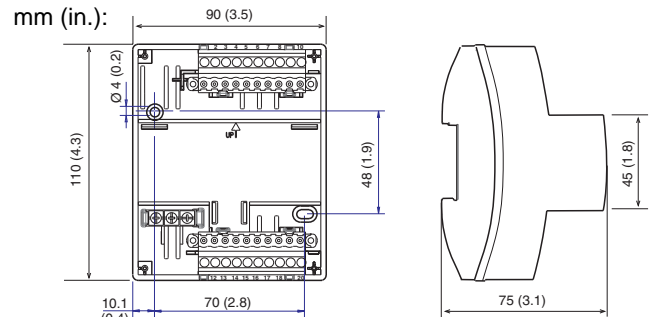

- LED digital input status indicators (TAC Xenta 452 only):
 - Quantity
 - Color
- Manual override for analog outputs (TAC Xenta 452 only):
 - Quantity
 - Switch positions
 - Potentiometer range
- Communication:
 - Network
- Agency Compliances:
 - Emission
 - Immunity
- Safety:
 - CE
 - UL 916
 - ETL listing
 - Flammability class, materials
- Part numbers:
 - Electronics part TAC Xenta 451 UNCONF
 - Electronics part TAC Xenta 452 UNCONF
(with LED indicators and AO override) ...
 - Terminal part TAC Xenta 400
 - Operator terminal TAC Xenta OP



DESIGN

TAC Xenta 451/452 consists of a terminal and a circuit board mounted together (figure 1). All terminations of field wires are made to the terminal part only. Thus, the electronics may be removed for service without affecting the terminal connections.

Universal Inputs

The Universal Inputs can be individually configured as an Analog or Digital Input. A high and a low limit can be set for each Universal Input. If configured as Digital Inputs, the Universal Inputs may be used for sensing switch positions.

The Universal Input types are selected via the application program.

Thermistor Inputs

There are four sensor inputs designed for input from the TAC thermistor or other similar sensor.

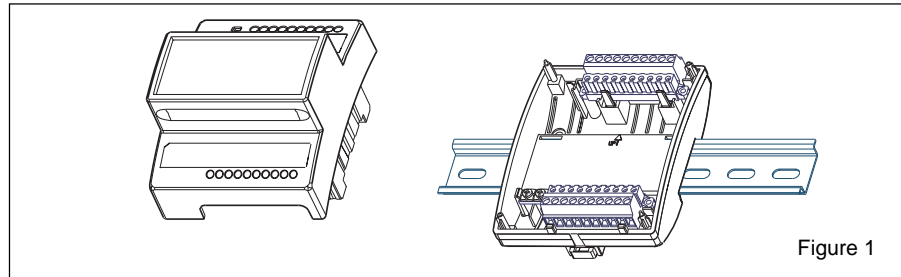

Figure 1

Analog Outputs

There are two Analog Outputs to control actuators and the connection to controllers. No external power supply is required.

LED indicators

There are two general LED indicators on the front of the module. One is red and lights up if there is a hardware fault. The other is green and blinks to indicate that the application program is running.

TAC Xenta 452 is equipped with four status indicators, one for each universal input when used as a digital input. The corresponding LED lights up when the input status is ON.

The LED colors, red or green, are individually selectable through switches under the front cover.

Also, there are two switches to manually override the analog outputs. In the MAN case a value 0-10 V is set with a potentiometer.

MOUNTING

TAC Xenta 451/452 is cabinet mounted on a TS 35 mm norm rail EN 50022. The Input/Output module consists of two parts: a terminal with screw terminals, and electronics with circuit boards. To simplify installation, the terminal can be pre-mounted on the cabinet, (see figure 1).

If the module is wall mounted, a wide range of standardized boxes are available.

CABLES

G and G0:

Min. wire size of 0.75 mm² (18 AWG).

C1 and C2:

The TP/FT-10, 78 system allows the user to wire the control devices with virtually no topology restrictions. The max. wire distance in one segment depends on the type of wire and the topology. For normal applications, using the Belden 85102 cable, the distance may be up to 500 m (1640 ft.).

For other applications, please refer to the TAC Xenta Network guide.

The wires are polarity insensitive, but must be a twisted-pair.

Terminals U1–U4, B1–B4, Y1–Y2:

Min. wire size 0.25 to 0.75 mm² (18 to 22 AWG).

Max. cable length 20 to 200 m (65 to 650 ft.).

(please refer to the TAC Xenta 400 I/O Modules Handbook for details).

INSTALLATION

There is a label on the front of the module with both the numbers and the names of the terminals (1 C1, 2 C2 and so on). The numbers are also shown in the plastic of the terminal part.

Service pin

To simplify network commissioning, there is a service pin on the electronic unit which, when pressed, identifies the unit on the network.

The unique Neuron ID is printed on a label on the rear of the unit.

Terminal connections

Term. no.	Term. name	Description
1	G	24 V AC/DC
2	G0	
3	C1	LONWORKS TP/FT-10, 78
4	C2	
5	U1	Universal input
6	M	Measur. neutral
7	U2	Universal input
8	U3	Universal input
9	M	Measur. neutral
10	U4	Universal input

Term. no.	Term. name	Description
11	Y1	Analog output
12	M	Output neutral
13	Y2	Analog output
14	B1	Thermistor input
15	M	Measur. neutral
16	B2	Thermistor input
17	B3	Thermistor input
18	M	Measur. neutral
19	B4	Thermistor input
20	–	

COMMUNICATION

LONWORKS connection

TAC Xenta 300/400 controllers and I/O-modules communicate with each other using a common bus, Echelon LONWORKS™ TP/FT-10, Free Topology, 78 kbps. A number of controllers can form a network and exchange data.

The additional I/O units also connect to the network and may be added as required. An I/O unit can only be associated with one controller.

The LONTALK™ protocol makes it possible to use Network Variables (NVs; for example I/O values) defined in foreign equipment.

TAC Xenta OP

The operator panel is also connected to the network and can thus act as an operator panel for other units in the network. The connection is made to the modular jack on the front of the TAC Xenta controller.

MAINTENANCE

Keep the module dry and clean it externally with a dry cloth when needed.

THERMISTOR INPUTS

Precision, measurement input:

-50 to -30 °C (-58 to -22 °F)	±4 °C (±7.2 °F)
-30 to -10 °C (-22 to 14 °F)	±2 °C (±3.6 °F)
-10 to 10 °C (14 to 50 °F)	±1 °C (±1.8 °F)
10 to 30 °C (50 to 86 °F)	±0.5 °C (±0.9 °F)
30 to 60 °C (86 to 140 °F)	±1 °C (±1.8 °F)
60 to 120 °C (140 to 248 °F)	±2 °C (±3.6 °F)
120 to 150 °C (248 to 302 °F)	±4 °C (±7.2 °F)

TAC and TAC products are trademarks and/or registered trademarks of TAC AB.

All other trademarks belong to their respective owners. Copyright 2002 © TAC AB. All rights reserved.