

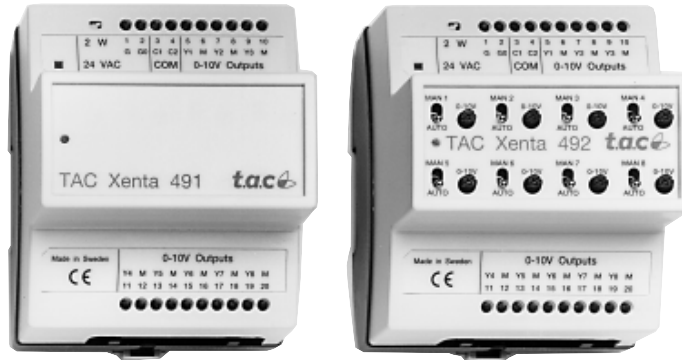

# TAC Xenta<sup>®</sup> 491/492

Analog Output Modules

4 Sep 2002



TAC Xenta 491 and 492 are Analog Output modules in the TAC Xenta family. They are used as expansion modules for the TAC Xenta controllers, connected by the common network.

Both modules have eight analog outputs.

In addition, TAC Xenta 492 is equipped with manual override for the analog output values.

TAC Xenta 491/492 is associated with a specific controller with the assistance of the TAC Menta graphical tool.

If there are several controllers and I/O modules in the same network, a special Device Configuration Tool PC program is used during installation.

The input/output status can be checked from the TAC Xenta OP operator panel connected to any TAC Xenta controller in the same network.

TAC Xenta OP has a display and a minimum number of push buttons.

## TECHNICAL DATA

Supply voltage ..... 24 V AC  $\pm 20\%$ , 50/60 Hz  
or 19–40 V DC

Power consumption ..... max. 2 W

Transformer sizing ..... 3 VA

Ambient temperature:

Storage ..... -20 to 50 °C (-4 to 122 °F)

Operation ..... 0 to 50 °C (32 to 122 °F)

Humidity ..... max. 90% RH non-condensing

Mechanical:

Enclosure ..... ABS/PC

Enclosure rating ..... IP 20

Dimensions ..... see diagram

Weight ..... 0.4 kg (0.88 lbs)

Analog outputs (Y1–Y8):

Quantity ..... 8

Control voltage ..... 0–10 V DC

Control current, short-circuit proof ..... max. 2 mA

Deviation ..... max 1%

Manual override for analog outputs (TAC Xenta 492 only):

Quantity ..... 8

Switch positions ..... MAN, AUTO

Potentiometer range ..... 0-10 V

Communication:

Network ..... Echelon LONWORKS<sup>®</sup> TP/FT-10, 78 kbps

mm (in.):

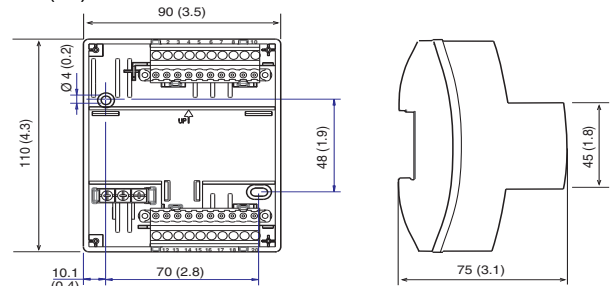

### Agency Compliances:

Emission ..... C-Tick, EN 50081-1, FCC Part 15

Immunity ..... EN 50082-1

Safety:

CE ..... EN 61010-1

UL 916 ..... Energy Management Equipment

ETL listing ..... UL 3111-1, first edition

..... CAN/CSA C22.2 No. 1010.1-92

Flammability class, materials ..... UL 94 V-0

### Part numbers:

Electronics part TAC Xenta 491 ..... 0-073-0301

Electronics part TAC Xenta 492

(with Analog Output override) ..... 0-073-0303

Terminal part TAC Xenta 400 ..... 0-073-0902



## DESIGN

TAC Xenta 491/492 consists of a terminal and circuit board mounted together (figure 1). All terminations of field wires are made to the terminal part only. Thus, the electronics may be removed for service without affecting the terminal connections.

### Analog Outputs

There are eight Analog Outputs to control actuators and the connection to controllers. No external power supply is required.

Furthermore, TAC Xenta 492 is equipped with eight switches to manually override the analog outputs. In the MAN case a value 0-10 V is set with a potentiometer.

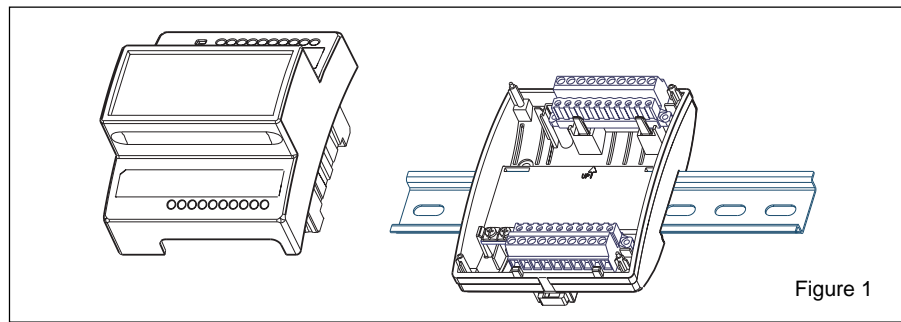

Figure 1

## MOUNTING

TAC Xenta 491/492 is cabinet mounted on a TS 35 mm norm rail EN 50022. The module consists of two parts: a terminal with screw terminals, and electronics with circuit boards. To simplify installation, the terminal part can be pre-mounted on the cabinet (see figure 1).

If the module is wall mounted, a wide range of standardized boxes are available.

### LED indicators

There are two general LED indicators on the front of the module. One is red and

lights up if there is a hardware fault. The other is green and blinks to indicate that the application program is running.

## CABLES

G and G0:

Min. wire size of 0.75 mm<sup>2</sup> (19 AWG).

C1 and C2:

The TP/FT-10, 78 system allows the user to wire the control devices with virtually no topology restrictions. The max. wire distance in one segment depends on the type of wire and the topology. For normal applications, using the Belden 85102 cable, the distance may be up to 500 m (1640 ft.).

For other applications, please refer to the TAC Xenta Network guide.

The wires are polarity insensitive, but must be a twisted-pair.

Terminals Y1–Y8:

Min. cross-sectional area 0.25 to 0.75 mm<sup>2</sup> (18 to 22 AWG).

Max. cable length 20 to 200 m (65 to 650 ft.).

(please refer to the TAC Xenta 400 I/O modules manual for details).

## INSTALLATION

There is a label on the front of the module with both the numbers and the names of the terminals (1 C1, 2 C2 and so on). The numbers are also shown in the plastic of the terminal part.

### Service pin

To simplify network commissioning, there is a service pin on the electronic unit which, when pressed, identifies the unit on the network.

If the pin is pressed continuously for more than seven seconds within 60 seconds after a restart, all values of the unit will be reset to the default values.

The unique Neuron ID is printed on a label on the rear of the unit.

### Terminal connections

Term. no.	Term. name	Description	Term. no.	Term. name	Description
1	G	24 V AC/DC	11	Y4	Analog output 0-10 V
2	G0		12	M	Output neutral
3	C1	LONWORKS	13	Y5	Analog output 0-10 V
4	C2		14	M	Output neutral
5	Y1	Analog output 0-10 V	15	Y6	Analog output 0-10 V
6	M	Output neutral	16	M	Output neutral
7	Y2	Analog output 0-10 V	17	Y7	Analog output 0-10 V
8	M	Output neutral	18	M	Output neutral
9	Y3	Analog output 0-10 V	19	Y8	Analog output 0-10 V
10	M	Output neutral	20	M	Output neutral

## COMMUNICATION

### LONWORKS connection

TAC Xenta 300/400 controllers and I/O-modules communicate with each other using a common bus, Echelon LONWORKS® TP/FT-10, Free Topology, 78 kbps. A number of controllers can form a network and exchange data.

The additional I/O units also connect to the network and may be added as required. An I/O unit can only be associated with one controller.

The LONTALK® protocol makes it possible to use Network Variables (NVs; for example I/O values) defined in foreign equipment.

## MAINTENANCE

Keep the module dry and clean it externally with a dry cloth when needed.

TAC and TAC products are trademarks and/or registered trademarks of TAC AB.  
All other trademarks belong to their respective owners. Copyright 2002 © TAC AB. All rights reserved.